



Lasertack

New Laser Generation

MSL-FN-xxx-AOM

HIGH FREQUENCY MODULATED SINGLE LONGITUDINAL MODE LASER

High frequency modulated laser system has such characteristics as quick modulation rate, high extinction ratio, easy coding and convenient use. Laser modulation frequency of this laser system can be up to 1MHz, It is mainly used in such fields as laser text-image processing, laser lithography, laser phototypesetting, and laser digital communication. It is suitable for OEM system integration and scientific research laboratories etc.



SPECIFICATIONS

Wavelength (nm)	473 ± 1	532 ± 1	556 ± 1	561 ± 1	671 ± 1
Output power (mW)	>1,10,20,...,50	>100,150,...,200	>1,10,20,...,50	>1,10,20,...,50	>1,10,20,...,150
Power Stability (rms,over 4 hours)	<1%,<3%,<5%				
Transverse mode	Near TEM ₀₀				
Longitudinal mode	Single				
Spectral linewidth (nm)	<0.00001				
Coherent length (m)	>50				
Optical Noise (rms,1~20MHz)	<0.5%				
M ² factor	<1.5				
Beam divergence, full angle (mrad)	<1.5				
Beam Diameter at the aperture 1/e ² (mm)	~3.0				
Polarization ratio	> 100:1				
Warm-up Time (minutes)	<10				
Pointing stability after warm-up (mrad)	<0.05				
Beam height from base plate (mm)	24.8				
Operating temperature(°C)	10~35				
Power supply (90-264VAC)	PSU-H-FDA-AOM				
Modulation	>1MHz				
Expected lifetime (hours)	10000				
Warranty	1 year				

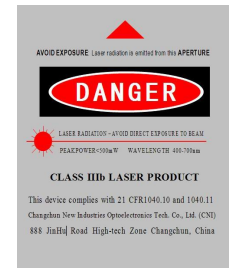

MxL-FN-xxx-AOM

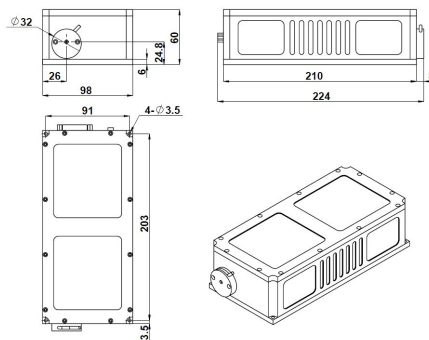

224(L)×98(W)×60(H) mm³, 1.9kg

PSU-H-FDA-AOM

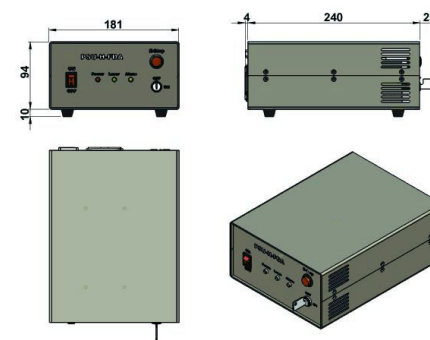

269 (L) ×181(W) ×104(H) mm³, 2.7 kg